

HYDRAULIC DRILLING UNIT

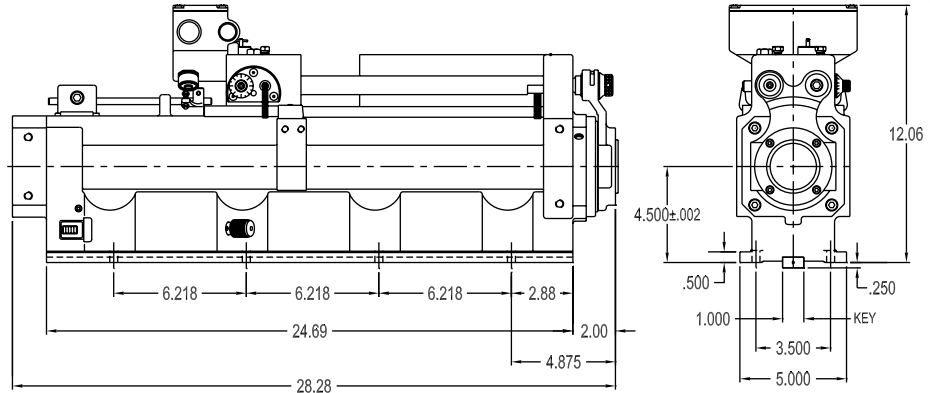
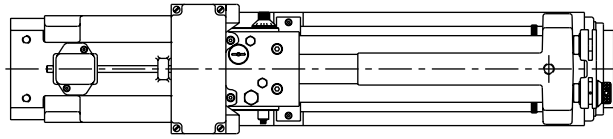

Models 6194, 6195

Specifications (Unit: inch)

Model No.	Thrust Adv./Ret. @ 500 psi	Stroke	Quill Dia.	Max. Spindle Speed	Min. Spindle Speed	Retract Feed	Oil Filler Style
6194	2750/1500	10"	3.500"	5000	80	Yes	N/A
6195	2750/1500	10"	3.500"	5000	80	No	N/A

Customizing A Hause Unit To Your Specs

Most Hause power feed units can be customized to best fit the needs of your unique applications. Using the worksheet at the back of this catalog and the information found on pages 36 - 49, you can spec out the Hause unit of your choice.

Model	Spindle	Drive	Belt/Pulley	Motor	Belt Housing	Special
6194	- BK	- A	- A	- Q	- AI	-
	Pgs. 36-37	Pgs. 38-39	Pgs. 40-41	Pgs. 42-44	Pg. 45	Pgs. 46-49

Example: 6194-BK-A-A-Q-AI This code specifies a Hydraulic Drilling unit (Model No. 6194) with a 10" stroke. Accessorizing this unit is a 1-3/8" Adjustable Adapter Spindle, Inline Shaft Drive, 5-Step "3V" Section Pulley, a 3 HP (1800 RPM) Nema "C" Flange Mounted Motor, mounted to the left side on an Overhead Belt Housing.

Features

- Concentric construction.
- Pressure compensating feed valves.
- Belt housing/position choices.
- Various spindle and drive choices.
- Pulley and RPM choices.
- Thrust up to 4250# available.
- Other options available.

All models can be used vertically or horizontally.

Feed rate
 Adv. 1/4" to 75" per minute.
 Ret. 1/4" to 60" per minute.
 Rapid travel: 190 I.P.M. approx.